



Reference design for SP6128A, a synchronous buck controller

Non-Isolated DC-DC SIP Modules: 3.0Vdc-5.5Vdc In, 0.9Vdc-3.3Vdc out, 15A

FEATURES:

- High Efficiency: 92.7% at 3.3V output,15A
- Small size and very low profile
50.8mm×6mm×12.71mm
(2in×0.236in×0.50in)
- 3V to 5.5V input voltage
- All ceramic capacitors design
- Negative or Positive remote On/Off
- Thermal shutdown protection
- Low output ripple max 20mV
- Output voltage adjustable with the trim function
- Low EMI noise
- Short circuit and over current protection using Hiccup mode and auto-restart
- Built in UVLO function
- Wide operation temperature range
-40°C to +85°C
- $\pm 0.15\%$ line regulation & $\pm 0.3\%$ load regulation

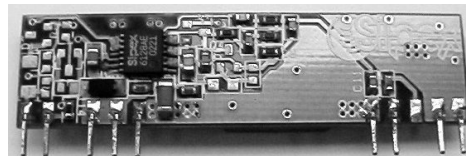
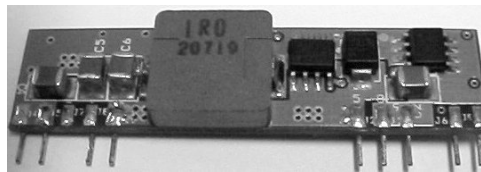

DESCRIPTION:

The SP6128A demo board design is a non-isolated dc-dc SIP module with very high efficiency at 15A output. It has smallest size compared with the current market products with the same power range and low EMI. Standard features include remote ON/OFF with the customer selectable positive and negative control, output voltage adjustment, soft start, over current and over temperature protection. This demo board proves that the SP6128A is a high-performance, but yet easy-to-use synchronous buck controller. It simplifies low voltage DC-to-DC power supply designs without compromising performance.

APPLICATION

- workstations, servers
- computers and peripherals
- distribution power architecture
- telecommunications equipment
- data processing and storage equipment
- LANs and WANs
- high performance data processing IC

SCHEMATIC:

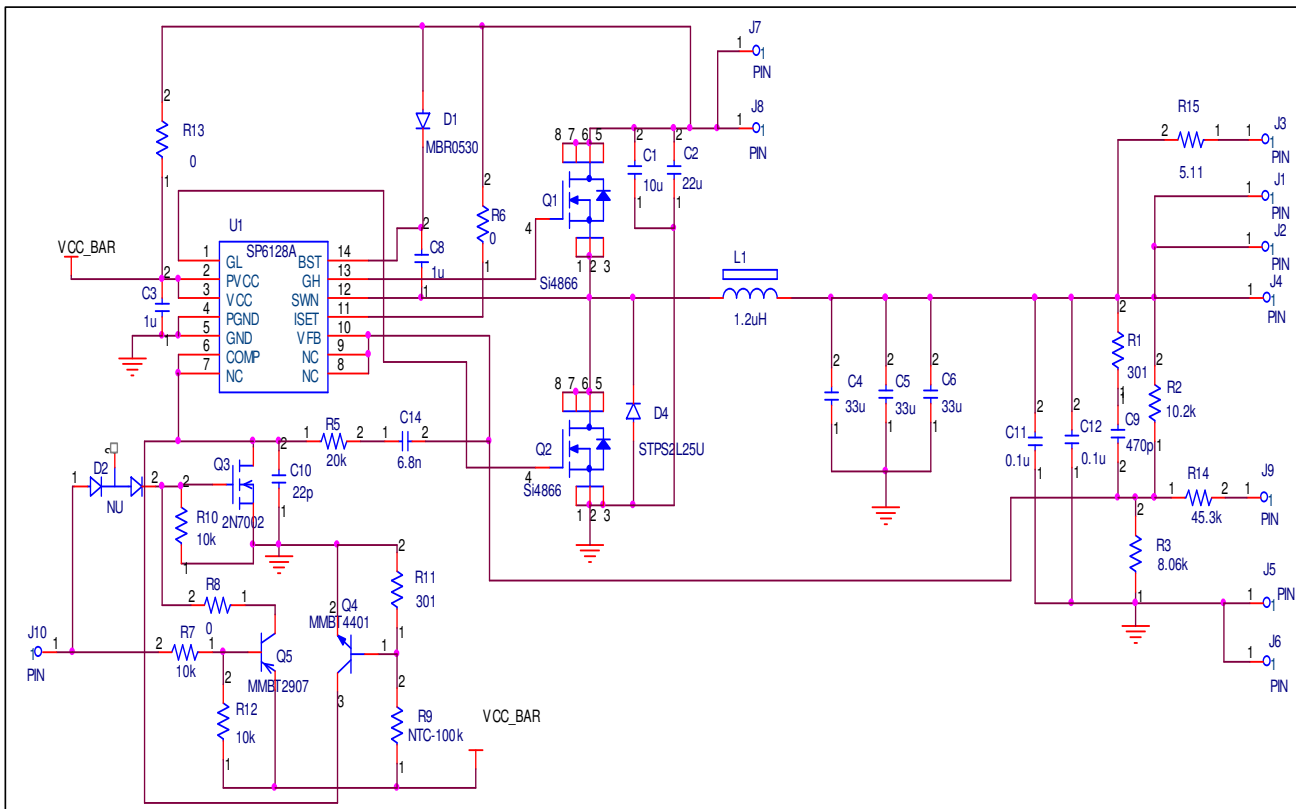

PCB Layout:

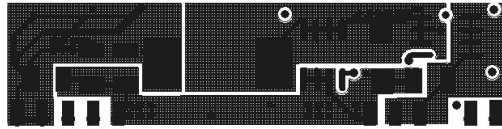

Top Layer

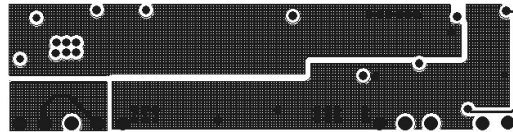

Internal-1 layer

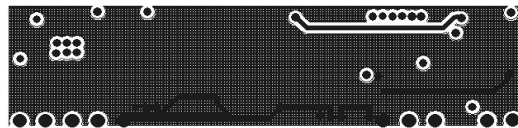

Internal-2 layer



Bottom Layer

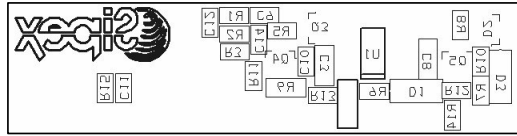
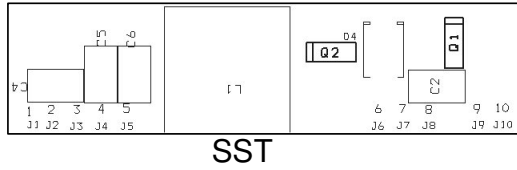

CHARACTERISTIC CURVE (1.8V output)

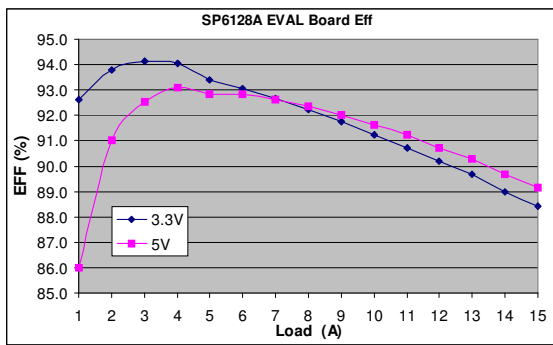

Figure 1

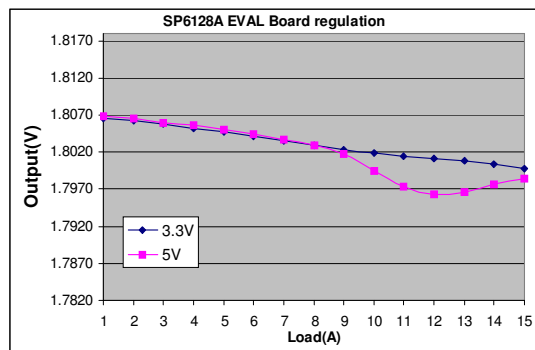

Figure 2

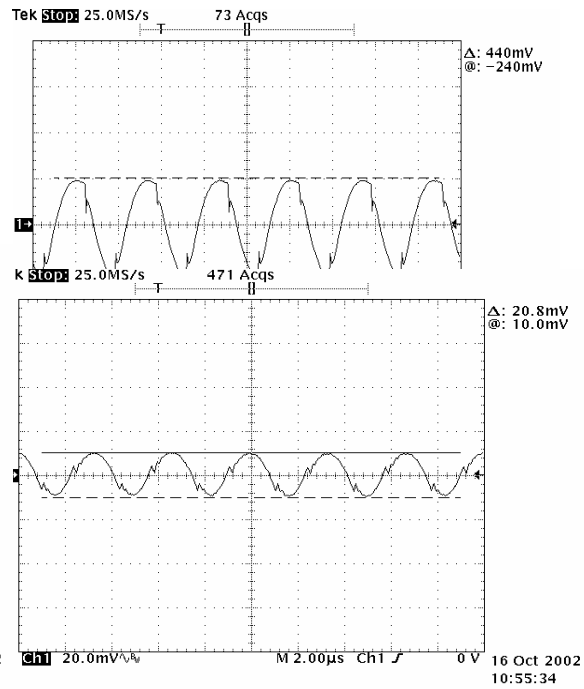
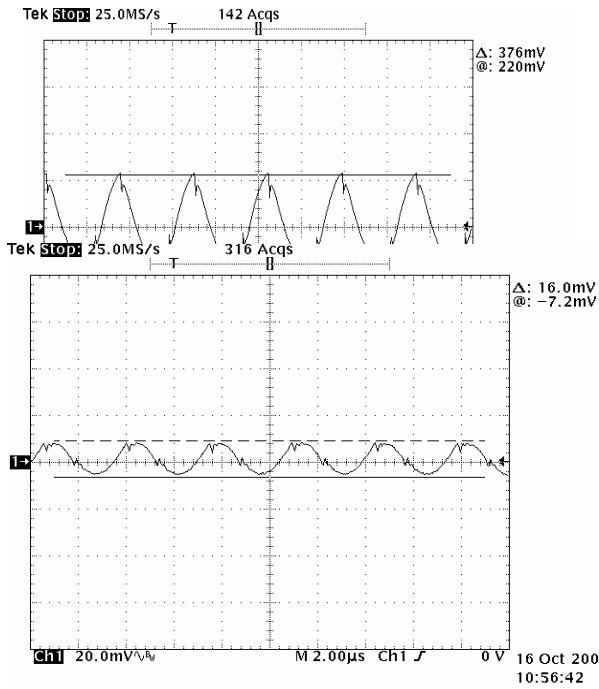

Figure 5: output ripple @ Vin=3.3V Io=15A

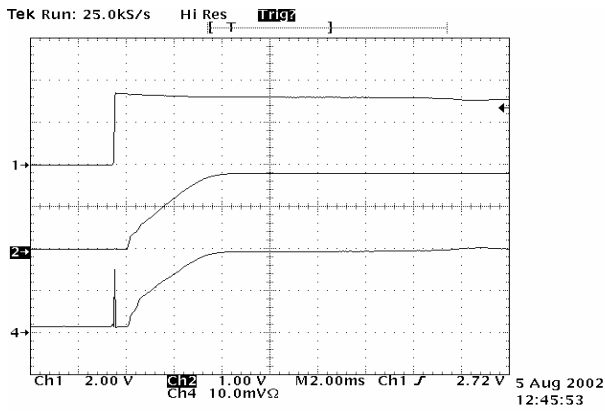

Figure 7: startup, Ch1:Vin, Ch2:Vout, Ch3:lin 2A/div @Io=15A

Figure 6: output ripple @ Vin=5V Io=15A

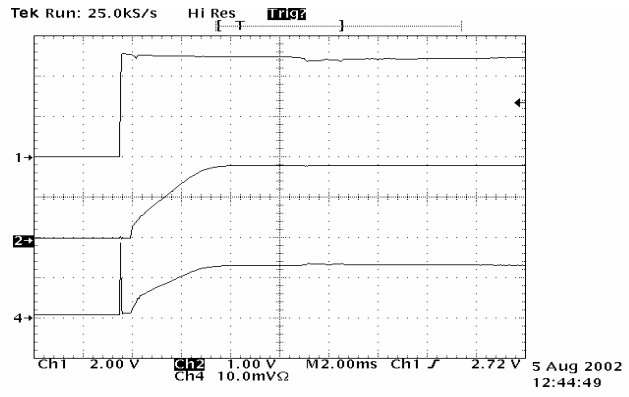

Figure 8 startup, Ch1:Vin, Ch2:Vout, Ch3:lin 2A/div @Io=15A

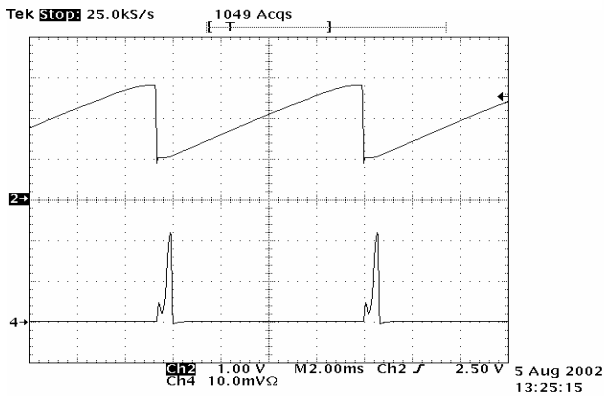

Figure 9: output short, Ch2: COM Ch4:lin 5A/div@Vin=3.0V

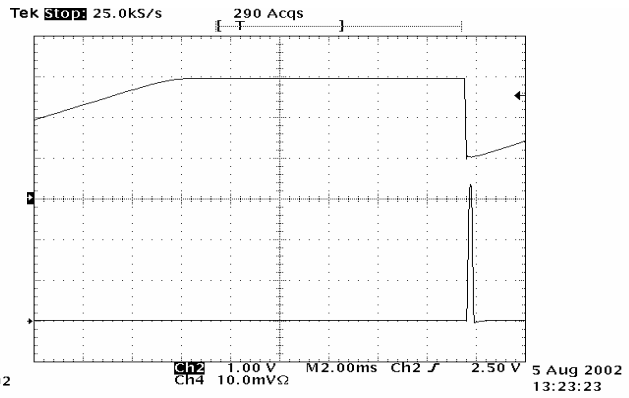
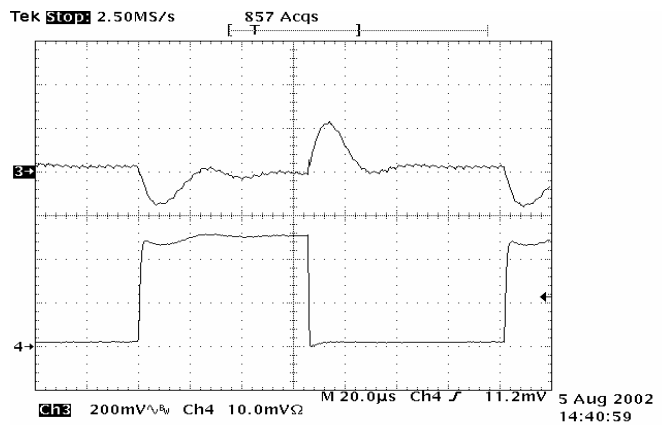
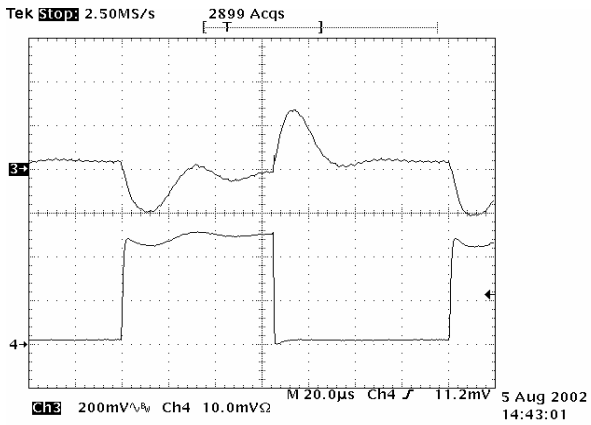

Figure 10: output short, Ch2: COM Ch4:lin 5A/div@Vin=5.0V



*short circuit protection tested at with $C_{in}=220\mu F$, Tantalum

Figure11: transient response, Ch1:Vout
Ch2:lout 2A/div load change
At 5A/us from 0.4A to 5A @
Vin=3.3V

Figure12: transient response, Ch1:Vout
Ch2:lout 2A/div load change
At 5A/us from 0.4A to 5A @
Vin=5V

ELECTRI

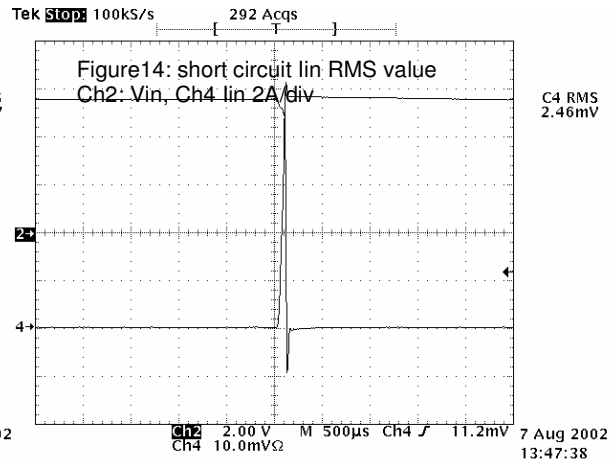
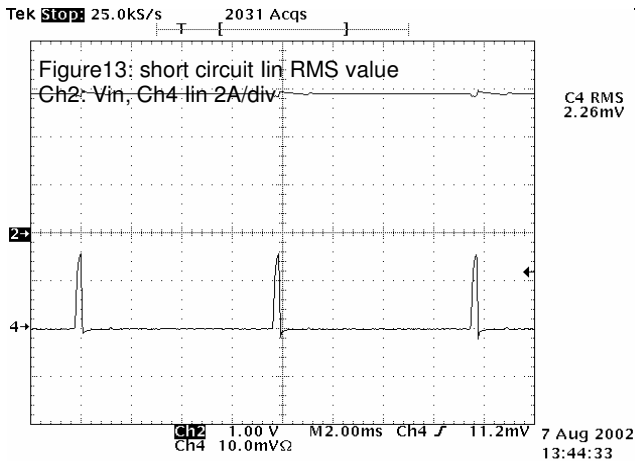

CAL SPECIFICATIONS

Parameter	Symbol	Min	Typ	Max	Units
Operating input voltage	Vin	2.9		6	Vdc
Input voltage ripple	Vinripple		250	300	mVp-p
Output voltage set point accurate				± 1.5	%
Output regulation					
Line regulation				± 0.1	%
Load regulation				± 0.3	%
Output ripple&noise			15	25	mVp-p
Output current	Io			10	A
Output current limit point			17	22	A
Over temperature protection			110	120	°C
Negative remote control:	Vrem	-0.7		0.3	V
Logic low-module on	Irem			100	μA
Logic high-module off	Vrem			2.4	V
	Irem			0.5	mA
Positive remote control:	Vrem	2.4			V
Logic high-module on	Irem			1	mA

Logic low-module off	Vrem Irem	-0.7		0.8 1	V μ A
Turn-on time				5	ms
Short circuit input current(RMS)				0.5	A
Output voltage trim range		-10		+10	% Vout ,nom

FEATURE DISCRIPTION

Output voltage trim function:

In this design, there is a trim pin that allows the customer to trim the output voltage to $\pm 10\%$ of the nominal voltage.

In the schematic on page 2, R3, R14, R2 and external trim resistor (Rtrim) comprise the trim function circuit. To trim-up, connect Rtrim between the trim pin and GND. The Rtrim value is equal to:

$$R_{trim} = \frac{0.8 \times R_2}{\Delta V} - R_{14}$$

To trim-down, connect Rtrim between trim pin and Vout. The Rtrim value can be derived from:

$$R_{trim} = \frac{0.8 \times R_2^2}{R_3 \times \Delta V} - R_2 - R_{14}$$

Deleted: e

Remote On/OFF:

This design allows the user to select positive or negative logic remote control. This demo board only implements the negative logic remote control circuit. To change to positive logic, remove Q5, R7, R8, and R12. and add D2.

Over temperature protection:

The over temperature protection will shut down the module when abnormal high temperature is detected by the circuit. The module will attempt to restart once the temperature cools down. The temperature set point can be adjusted by resistor R11.

Mechanical Outline Diagram

Dimensions are in millimeter (inch)

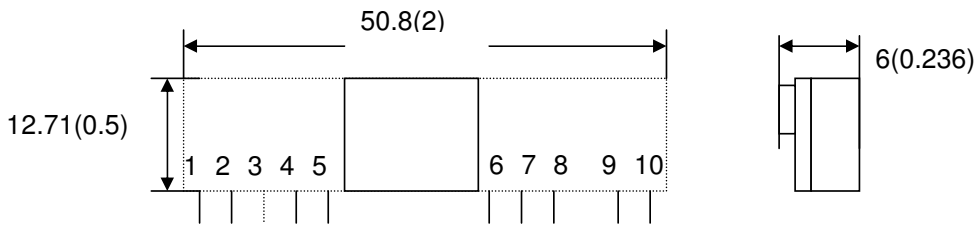

IN	FUNCTION
1	Vo
2	Vo
3	sense
4	Vo
5	GND
6	GND
7	Vi
8	Vi
9	Trim
10	Remote

*the pin out is not the same as standard

BILL MATERIAL

Item	Quantity	Reference	Part	Manufacture information
1	1	C1	10u	TDK C3216X5R0J106M
2	1	C2	22u	TDK C3225X5R1A226M
3	2	C3,C8	1u	TDK C2012X7R1C105K
4	3	C4,C5,C6	33u	TDK C3225X5R0J336M
5	1	C9	470p	TDK C1608C0G1H471J
6	1	C10	22p	TDK C1608C0G1H220J
7	2	C11,C12	0.1u	TDK C1608X7R1H104K
8	1	C14	6.8n	TDK C1608X7R1H682K
9	1	D1	STPS0520Z	ST Micro
10	1	D4	STPS2L25U	ST Micro

11	9	J1,J2,J3,J4,J5,J6,J7,J8,J9	PIN	
12	1	L1	SPM12550-1R0M220 SC5018-1R2M or	TDK Easy Magnetic
13	2	Q1,Q2	SI4866	Vishay
14	2	R1, R11	301	0603
15	1	R2	10.2k	0603
16	1	R3	8.06k	0603
17	1	R5	20k	0603
18	3	R6,R13, R8	0	0603
19	1	R14	45.3	0603
20	1	U1	SP6128A	SIPEX
21	3	R7,R10,R12	10K	0603
22	1	Q3	2N7002	ON semiconductor
23	1	Q4	MMBT4401	ON semiconductor
24	1	Q5	MMBT2907	ON semiconductor
25	1	R15	5.11	0603
26	1	R9	NTC-100K	TDK NTCG204CH104J

* For the low profile application,SPM12535-1R0M160 (TDK)or SC5015-1R2M (Easy magnetic) recommended for L1

EFFICIENCY ON THE DIFFERENT OUTPUT VOLTAGE

Input voltage	Output voltage	Efficiency (10A)	Efficiency(15A)	Internal Trim resistor
3.0-5.5V	0.9V	86.2%	83%	80.6K
3.0-5.5V	1V	87.3%	84%	40.2K
3.0-5.5V	1.2V	89%	84.6%	20.5K
3.0-5.5V	1.5V	90.8%	87.1%	11.8K
3.0-5.5V	1.8V	92.2%	89.2%	8.06K
3.0-5.5V	2.0V	92.7%	89.4%	6.81K
3.0-5.5V	2.5V	94.1%	91.8%	4.75K
4.5-5.5V	3.3V	95.6%	92.7%	3.24K



SIGNAL PROCESSING EXCELLENCE

Headquarters and sales office

22 Linnell Circle
Billerica, MA 01821
TEL: 978-667-8700
FAX: 978-670-9001
E-mail: sales@sipex.com

Sales office

233 South Hillview Drive
Milpitas, CA 95035
TEL: 408-934-7500
FAX: 408-935-7600

Application support

Jack Ni
TEL: 978-671-4644
Email: jni@sipex.com
